

# GORILLA® MATRIX (COLUMN/POST) INSTALLATION GUIDELINES



## FEATURES:

- Matrix™ Baseplate can accommodate a variety of internal supports, including 3.5" and 2.375" diameter metal tubes, and 4"x 4" (nominal) wood posts.
- Gorilla Columns/Posts are available in a variety of dimensions, including 8.4" Round, 6.625" Round, 8" Square, 6.5" Square and 5" Square PVC columns.
- Transition assemblies allow for a variety of additional looks including:
  - 8" Square to 6.5" Square
  - 8" Square to 6.625" Round
  - 8" Square to 5" Square
  - 6.5" Square to 5" Square
- Standard 9' and 10' lengths

## REQUIRED TOOLS AND MATERIALS:

- Safety Glasses
- Power drill/driver with 5/16" hex drive and #2 phillips head drive
- 3/4" spade bit and 3" drive extension (required for Side-Mount bushing installation)
- #3 Phillips-head screwdriver
- Measuring Tape
- Non-marking Rubber Mallet
- Waymark PVC Cement
- Surface mounting fasteners are NOT included. Required fasteners will depend on the porch/roof material and structure for the project
- Reciprocating Saw with fine-tooth (hack-saw) blade if column is to be cut to length.

The Gorilla Column/Post system is intended for use as a porch post, with at least one side of the porch deck and roof attached to an adjoining building or structure to provide lateral support. Gorilla Columns/Posts are NOT intended to be used for free-standing structures, i.e. pergolas, gazebos, etc. It is the installer's responsibility to consult the local building codes prior to installation of Gorilla Columns/Posts.

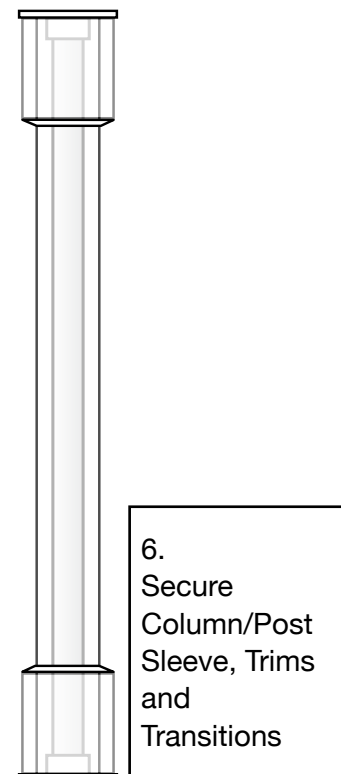
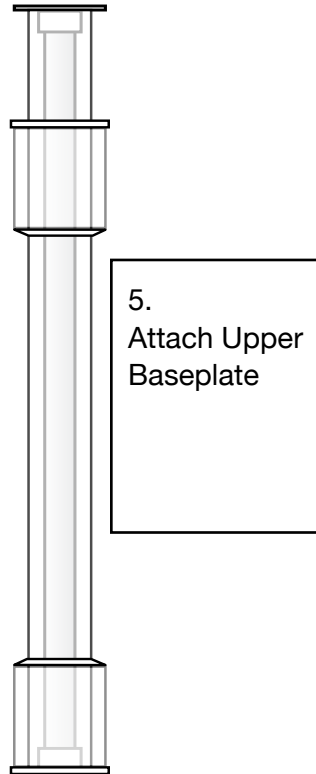
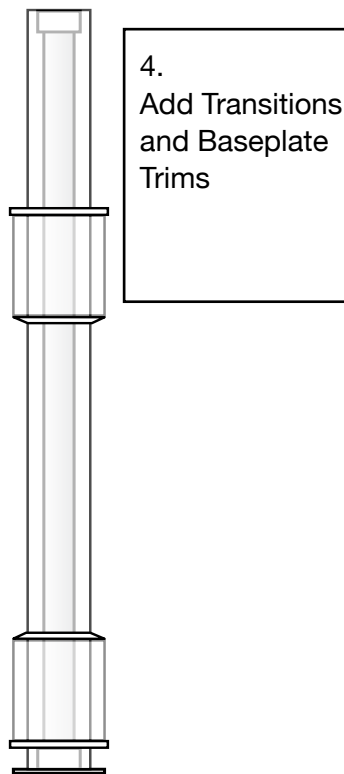
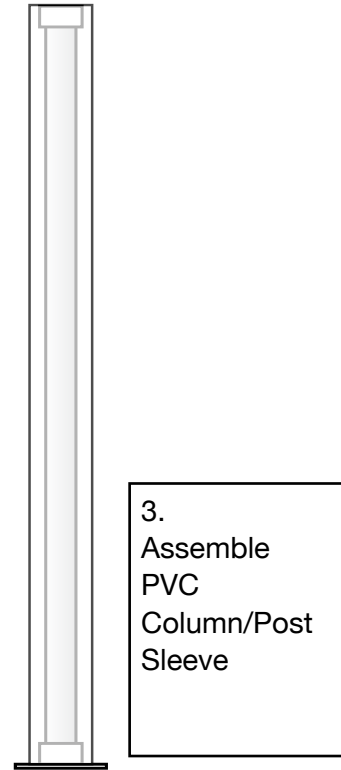
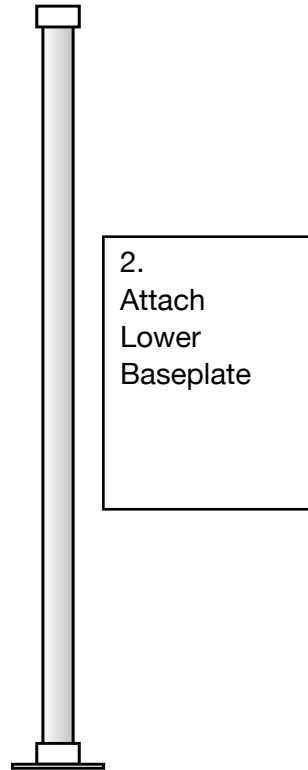
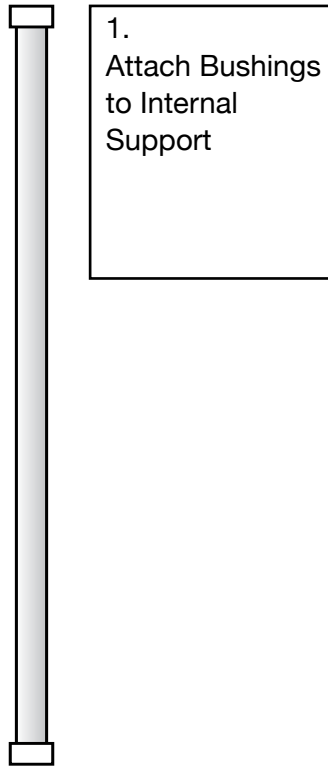

## 1. COMPONENT DESCRIPTION

Each Gorilla Column/Post requires the following:

- A. Matrix™ Universal Baseplate Kit. Each kit includes:
- (2) Matrix™ Universal Baseplates
  - (2) Structural support Bushings
  - (2) Universal Base Trim
- (1) Hardware pack:
- (8) 1-1/2" #12 hex-head self-drilling screws
  - (8) 3/4" #14 Phillips-head sheet metal screws
  - (8) 1" #10 self-drilling screws

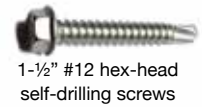

1-1/2" #12 hex-head self-drilling screws



3/4" #14 Phillips-head sheet metal screws



1" #10 self-drilling screws

Matrix Baseplate



Bushing



Universal Base Trim

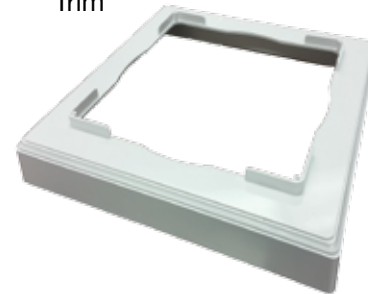

- B. Internal support member  
2.375" or 3.500" diameter, 13 ga. galvanized steel tube
- C. PVC column/post sleeve  
Column (round) sleeves are available in 8.4" or 6.625" diameters  
Post (square) sleeves are available in 8" x 8", 6.5" x 6.5" or 5" x 5" dimensions

- D. Column/Post trim rings (2)

Base trim rings are selected according to the chosen column/post sleeve, or transition sleeve, if a transition assembly is used.

- E. Transition assembly components

Transition assemblies can be made by using sections of PVC column/post sleeves and transition trim rings. The transition sleeve is cut to length and installed at either or both ends of the column/post assembly. For example, the column/post can transition from an 8" x 8" square at the base to a 6.625" diameter round. Transition trim rings are available in the following combinations:

- 8" square to 6.5" square
- 8" square to 6.625" round
- 8" square to 5" square
- 6.5" square to 5" square

## 2. PREPARATION

### A. General

- Review local building codes.
- Handle PVC components with care. Do not place on rough surfaces during assembly, or PVC surface may be scratched
- Measure the opening where the Gorilla Column is to be installed. Standard Gorilla Column lengths are 9' and 10'; if using an alternate length, deduct 3/8" from the PVC column/post sleeve length and 5/8" from the internal support length to account for the thickness of the Baseplates and support bushings.
- NOTE: Gorilla Columns are assembled and then placed in the final location. Tilting up the column will require approximately 1" clearance beyond the nominal 9' column height.
- The baseplate cover and column trim ring should be assembled using PVC cement prior to assembly and set aside until ready for installation.
- If the assembly is to include Transitions, the PVC transition sleeve and trim should be assembled using PVC cement and set aside until ready for installation.

### B. Porch Structure/Blocking

Determine the location of the columns and ensure that adequate support is available for securely attaching the column baseplates to the porch roof and deck structure. See Figure 2.1 for suggested blocking in a wood structure. If columns are to be set on a concrete surface, determine the concrete anchor locations.

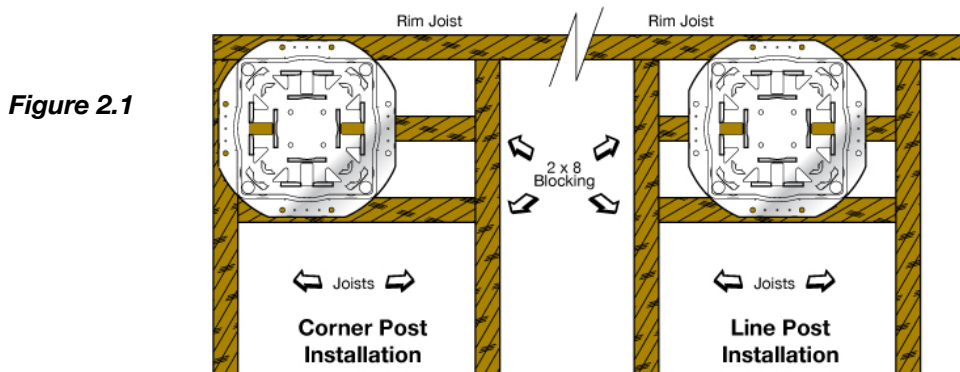

Figure 2.1

### C. Support Bushing Assembly

Fit the support bushings to the ends of the internal support. Fit should be snug. Laying the support assembly on a flat surface will assure that the two bushings are lined up square on both ends. See Figures 2.2a and 2.2b.

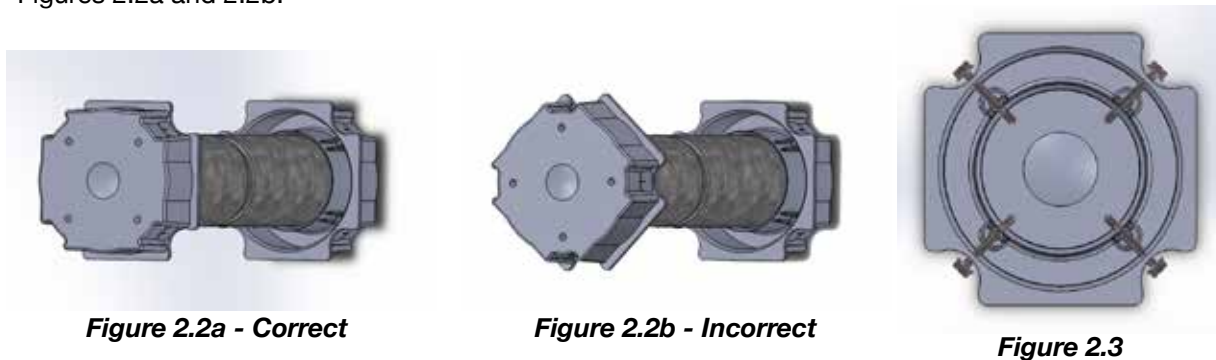

Figure 2.2a - Correct

Figure 2.2b - Incorrect

Figure 2.3

Attach bushing to internal support using four (4) 1-1/2" hex-head self-drilling screws placed in the corners of the bushing. See Figure 2.3. Repeat for other end of internal support.

### 3. COLUMN/POST ASSEMBLY

#### A. Connect Baseplate to Internal Support

Place a Matrix™ universal baseplate onto one end of the bushing/support assembly. Use four (4) ¾" #14 Phillips-head screws through the bottom of the baseplate into the bushing. It is recommended that the ¾" screws be inserted manually, rather than with a drill or power driver, in order to avoid stripping material from the inside of the bushing. See Figure 3.1.

NOTE: Do NOT attach the second baseplate to the opposite end of the Internal Support until the column assembly is completed. Further assembly requires that one end of the column be open to allow installation of the PVC Column/Post sleeve, Transition assemblies, and Trim pieces.

#### B. Install Column/Post Sleeve

Slide the PVC Column/Post sleeve over the Internal Support and fit into the corresponding tabs on the attached Matrix™ universal baseplate. Secure the column sleeve to the baseplate using four (4) 1" self-drilling #10 screws through the baseplate tabs (one screw for each side of the baseplate). See Figure 3.2.

#### C. Place Transitions and Trims on Column Assembly

All Transition and Trim pieces should be placed on the column sleeve in their proper orientation before installation of the second baseplate. Generally, Transitions and Trims are installed in the following order:

- 1) Baseplate cover and trim ring for lower baseplate
- 2) Transition Assembly for lower baseplate, if applicable
- 3) Transition Assembly for upper baseplate, if applicable
- 4) Baseplate cover and trim ring for upper baseplate

#### D. Attach Top Baseplate and Secure PVC Column/Post Sleeve

Align upper baseplate with internal support bushing and PVC column sleeve. Attach using four (4) ¾" #14 Phillips-head screws through baseplate. Secure the PVC Column/Post sleeve to the corresponding tabs located on the upper baseplate using four (4) 1" self-drilling #10 screws

Figure 3.1

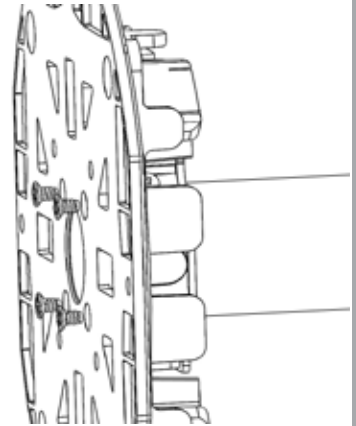
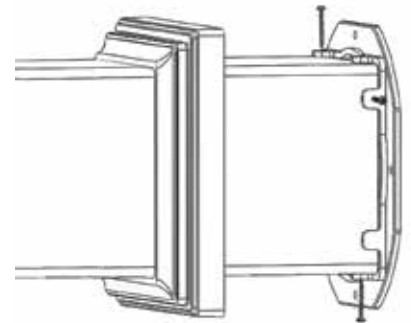

Figure 3.2





## Alternative Baseplate Connection (Side-Mount)

You can increase the Gorilla Column's uplift resistance by connecting the Internal Support Bushing to the Matrix Baseplate through the innermost set of the Baseplate mounting tabs. This "Side-Mount" connection requires an alternative installation method, described below:

With the Side-Mount method, the Internal Support, Bushing and Baseplate are connected through the Baseplate mounting tabs using the four (4) 1 1/2" #12 hex-head self-drilling screws, as shown in Figure A-1, below:

Figure A-1

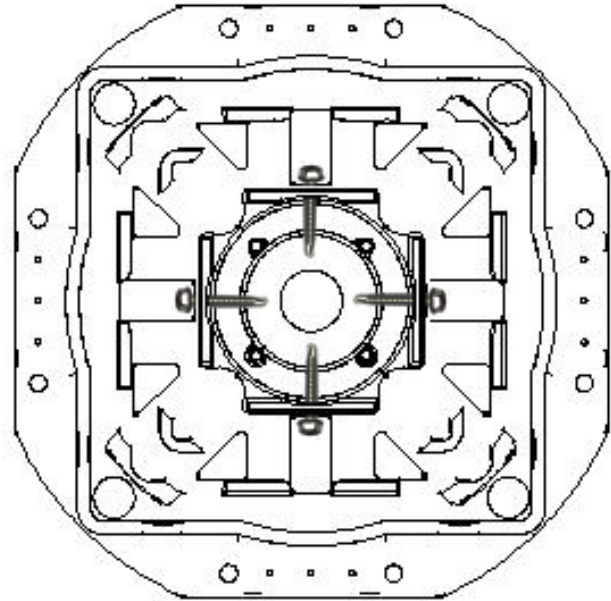

1. Confirm that the Bushings are square to the Internal Support and aligned (as described in the main Installation Guidelines at section 2.C.). Do **NOT** attach the bushing to the support with screws at this time.

2. Set the Bushing in the Baseplate mounting tabs. Connect the baseplate, bushing and internal support with four (4) #12 hex-head screws, one through each base plate mounting tab and through the side of the bushing. The screws should be set no higher than the upper ends of the two parallel lines molded on the Baseplate mounting tabs.

3. To simplify the final column assembly, it is recommended that the second Baseplate be attached (the self-drilling screws can tap holes in the internal support), and then removed until final assembly. Leave the bushing in place on the internal support and remove the base plate. Mark the base plate and Bushing, so they can be reinstalled in the same orientation.

4. For final assembly, make a 3/4" diameter access hole at the edge of the PVC column sleeve in order to allow access to the (pre-drilled) upper baseplate connection points. The access hole must be placed close to the end of the column sleeve so that it will be hidden by the Baseplate or Transition trim pieces at final assembly. NOTE: A round sleeve only requires one access hole, which can be rotated to face each connection point. A square sleeve requires an access hole at each of the four connection points.

5. After the column sleeve, base trims, and transitions have been assembled, replace the upper Baseplate on the open end of the Column Assembly. Use a 3" extension and hex-head drive through the access holes to reset the hex-head screws into the Baseplate and Internal Support.

6. Proceed with the installation by securing the column to the porch structure and the PVC Sleeve and Transitions to the Baseplate mounting tabs.

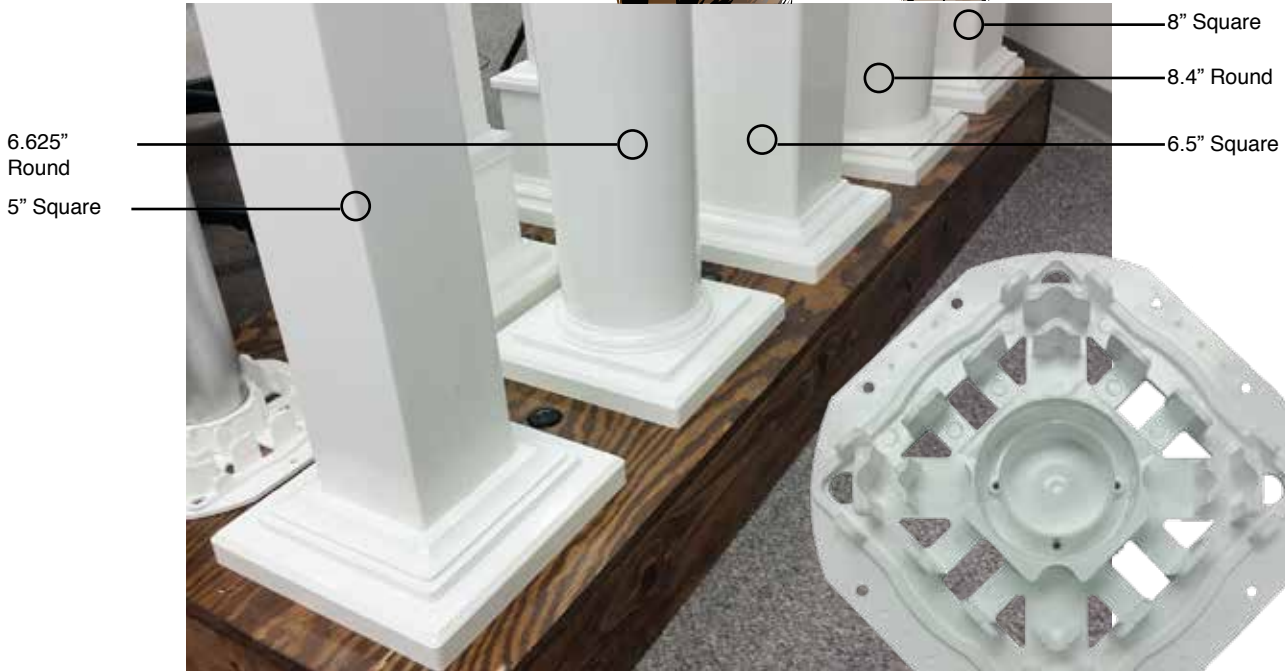

6.625\"  
Round  
5\" Square

8\"  
Square  
8.4\"  
Round  
6.5\"  
Square



6.5\"  
Square  
to 5\"  
Square  
8\"  
Square  
to 5\"  
Square

8\"  
Square  
to 6.5\"  
Square  
8\"  
Square  
to  
6.625\"  
Round

**Gorilla Matrix is the single mounting plate needed to install every size column or post from 5" x 5" up to 8.4" round.**